

Front Panel View



Rear Panel View



Features & Benefits

As an active forward path fully modular distribution device, the unit provides up to 32 output ports with an ultra-flat signal response for delivery to an optical transmitter in the frequency range 48-1218MHz.

- Provides up to 5 Input Signals and up to 32 outputs
- Variety of Amplifier's Gain
- High reliability due to load-sharing redundant power supplies and RF amplifier arrangement
- Simplifies engineering and architecture design challenges and allows for duplication between sites.
- Normal close Alarm contacts for each active device component
- Significantly reduces the use of external jumper cables, power consumption, rack space, and manpower hours of labor.
- Optional Gain Adjustment
- Optional Web or SNMP monitoring
- Custom designs welcomed.

The ASF-203 series of Forward Path Active Distribution Devices (Active Splitter) are designed for typical usage within headend and hub site environments. Devices are built within a standard 19" EIA rack, are compact, and modular while using only 2 rack unit of space. The system provides an ultra-flat RF output signal for distribution to optical transport. It is an extremely reliable and cost effective platform and has a very flexible feature set required for today's modern cable TV plant.

All models in the FDS Series include a redundant power supply arrangement. The new ASF-203 devices have two amplifiers connected in redundant configuration to increase reliability of whole unit.

The new designed microcontroller signal monitoring and control circuits with calibration procedure sufficiently reduces potential malfunction of RF sensing switch. That problem of wide range input signal devices can be caused by not equal RF power sensitivity of detectors and their non equal interception points.

As a completely active distribution device, the solution allows for architecture design consistency amongst multiple hub sites while saving precious rack space. As an integrated system solution, the units significantly reduce external cabling. A flexible feature set allows for moves, adds, and changes as the cable network evolves; ready to solve the challenge of complex RF combining and splitting schemes.

The units are designed for active distribution of up to 5 input signals which are combined and split for distribution up to four separate groupings of 8 outputs each.

Due to the availability of inserting various amplifiers gain blocks, Input and Output sections the achieved output level operational range provides flexibility for compatibility with all types of optical transmitters or another application design. Multiple Test Ports, Amplifiers and Power Supplies status LED's are provided on the front panel for technician friendly maintenance and signal control.

The system is uniquely configured to work in conjunction with our passive narrowcast units. See the PNF-108, PNF-111 and PNF-112 Series of Narrowcaster Combiner's solutions.

The modular arrangement allows for design flexibility, optimum performance results, and compliance with site requirements. Units offered with options such as various amplifier gain modules, input / output module configurations, as well as a choice of universal 90-260VAC or -48VDC power.

Models include a standard feature for contact closure pin out alarms which will monitor the performance status of amplifiers, power supplies and RF switch.

Please contact us for additional technical support or product information.

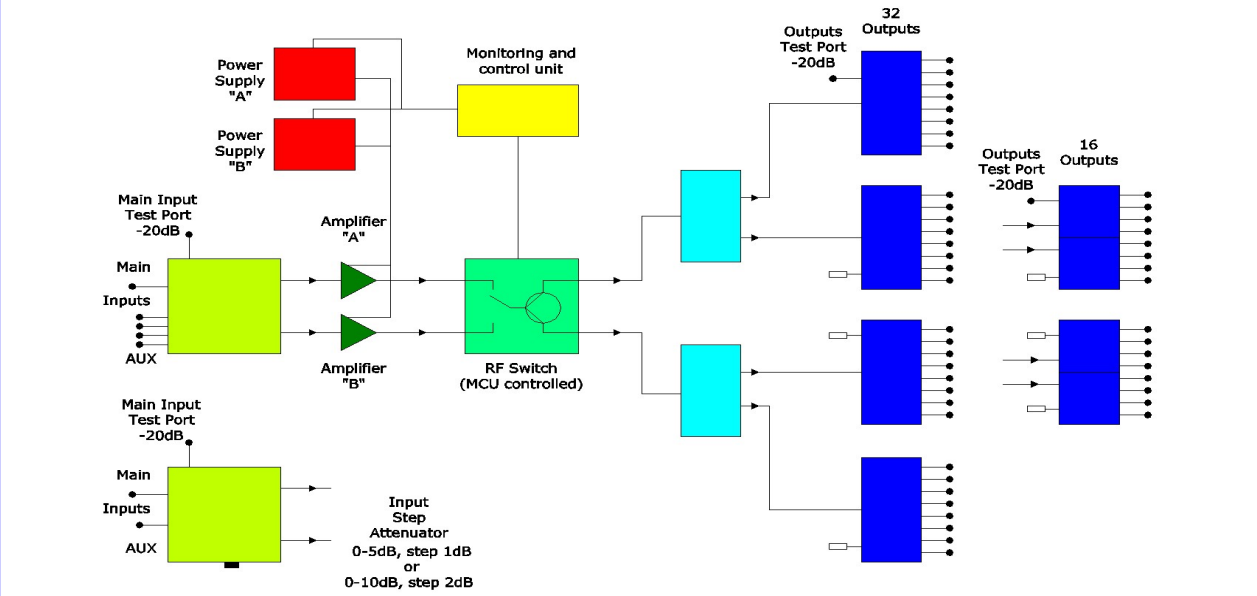

Technical Specification:

| <i>Parameters</i> | <i>Units</i> | <i>Spec</i> |
|---|--------------|-----------------|
| Bandwidth | MHz | 48 - 1218 |
| Number of Inputs | | 2 |
| Number of Outputs | | 32 |
| Insertion Loss "Main Input" - Output (32 Out, 27 dB Gain Amplifier) | dB | 1.0±0.5 |
| Gain Adjustment, max | dB | -10 |
| Gain Adjustment Step | dB | 2 |
| Insertion Loss Flatness | dB | ±0.5 |
| Insertion Loss "AUX Inputs" - Outputs | dB | 22.0±0.5 |
| Return Loss all Ports, min | dB | 20 |
| Isolation between Inputs and Outputs | dB | 30 |
| Recommended Input Signal Level (132 ch., flat): | dBmV | |
| System Input | | 20 |
| AUX Inputs | | 40 |
| C/N Ratio (PAL and SECAM) | dB | 63 |
| Input Noise Figure, max | dB | 10 |
| Control Output (DB-15) | | NC Contact each |
| Powering: | | |
| Universal | VAC | 98-240/50-60Hz |
| DC | VDC | -48 |
| Dimensions | inch | 3.5Wx19Wx14D |
| Weight | lb | 14 |

Ordering Information:

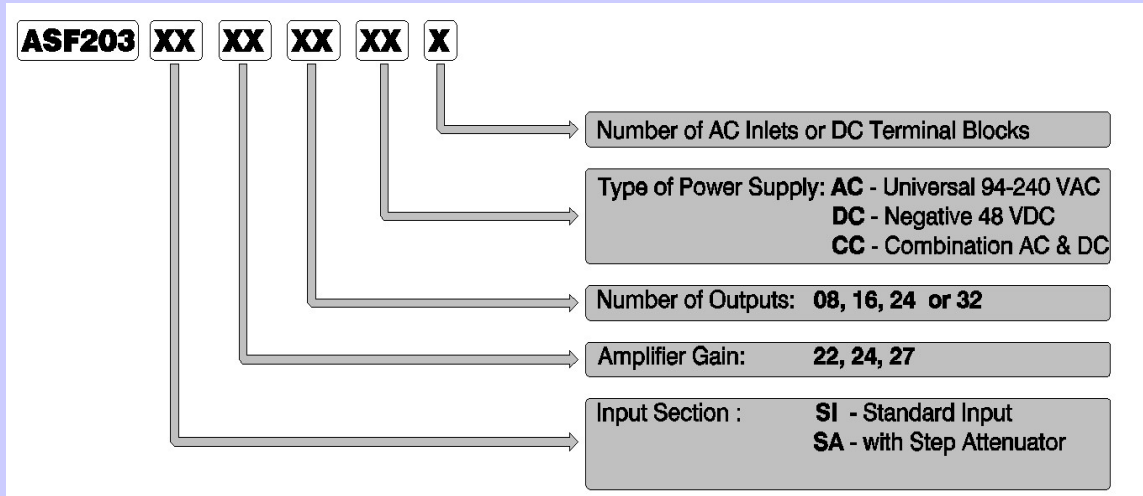

Part Number Example:

ASF203-SI-27-32-AC-2:

| | |
|---------|-----------------------------|
| ASF-203 | ASF-203 device |
| SI | Standard Input |
| 27 | 27 dB Gain |
| 32 | Number of Outputs |
| AC | Universal 90-240VAC/50-60Hz |
| 2 | Two AC power Inlets |