

DOCSIS 3.x Compliant



Features & Benefits

to 8 discrete combining modules to accommodate Narrowcast additions.

- Fully Modular design for easy replacements and upgrades
- Add 3 Separate Narrowcast Inputs, such as VOD, VoIP, or HSD to each Output.
- The compact solution occupies only 1RU with 8 groups of independent outputs.
- Each Output group has two equal outputs.
- Low Insertion Loss from Inputs to outputs.
- Simplifies engineering and architecture design challenges and allows for site duplication.
- With multiple configuration options for signal balancing, the units are compatible with a wide range of optical transmitters.
- Ideal solution when paired together with ASF-100 and 200 Series devices.
- Custom designs welcomed.

THREE YEAR PARTS AND LABOR WARRANTY INCLUDED

- A single Broadcast Input is split

The new PNF-112 fully modular Narrowcast Extender routes a single broadcast feed into 8 independently wired modules for insertion of up to 3 narrowcast services per module. Narrowcast services can be individually selected for each of the 8 output section combining modules. Each module provides two equal outputs, with 16 outputs per 1RU unit. Outputs can be directly connected to feed optical transmitters and measurement equipment. The PNF-112 unit is designed to eliminate existing services interruptions when adding or changing narrowcast services.

The integrated 1RU design with access to modules from chassis front and back panels simplifies installation, minimizes rack space and setup time. The passive design allows unit stacking to maximize density. Front panel mounted test ports (8) are present for each group of combined outputs and 1 test port for the broadcast input signal. The unit provides high isolation between module input ports and between modules with excellent return and insertion loss performance.

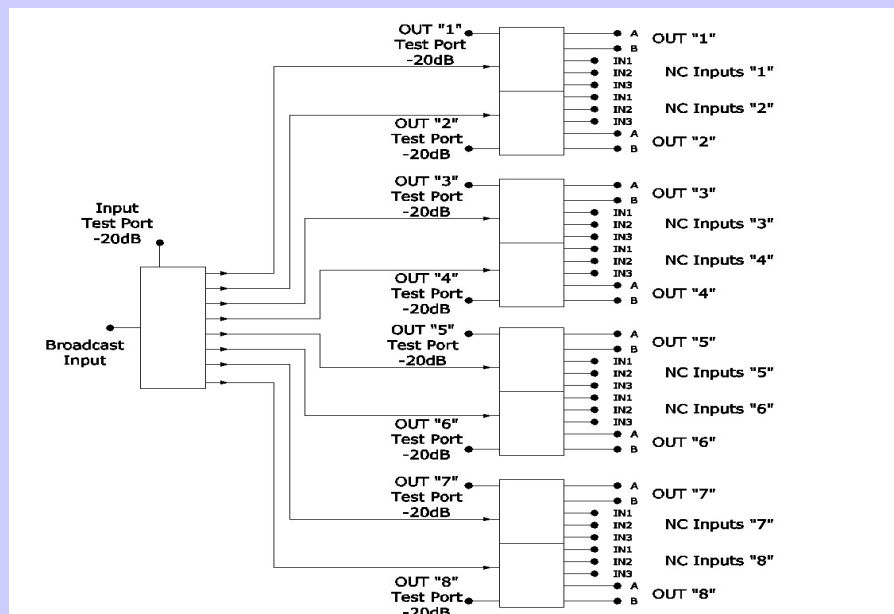

PNF-112 Block Diagram

DOCSIS 3.x Compliant

The **PNF-112** devices offered in two different versions: with Standards 40 - 1002 MHz working frequency band and Extended up to 1218 MHz - **PNF-112.1**.

Technical Specification:	PNF-112	PNF-112.1	
Parameter	Specifications		Units
Bandwidth	40 - 1002	40-1218	MHz
Number of Broadcast Inputs	1		
Number of Output Groups	8		
Number of Outputs in Each Group	2		
Number of Narrowcast Inputs in Output Group	3		
Insertion Loss:			
Broadcast Input - Output	20.0±0.5	20.5±0.5	dB
Narrowcast Input - Output	20.0±0.5	20.5±0.5	dB
Insertion Loss Flatness	±0.5		dB
Test Port Insertion Loss	20.0±0.5		dB
Return Loss, all Ports, min	20		dB
Isolation Between Narrowcast Inputs in same Output Group	30		dB
Isolation Between Narrowcast Inputs in different Output Groups	65		dB
Isolation between Narrowcast Inputs and Broadcast Input	55		dB
RFI, min	100		dB
Operation Temperature	0 -50		°C
	32 -122		°F
Dimensions	1.75Hx19Wx12D		inch
Weight	9.8		lb

As mentioned above all parts are modular for easy replacement, upgrade and modifications for different number of Outputs and Narrowcast Inputs for Output section - similar like **PNF-108** but modular.